



Pile Driver Caps made from Nylatron® GSM 12P outperform wood and steel caps

Pile driver pads are used to prevent damage to the pile and the piling hammer. Fillers are usually made of hardwood - Azobe, for example. The disadvantage of Azobe however, is the significant energy loss it causes (30% to 40%) and its relatively short useful life. Azobe is also difficult to remove from the pile pad.

Working with key piling companies, Quadrant EPP has developed the Nylatron® GSM 12P pile driver cap, which has several unique properties. With a Nylatron® GSM 12P pile driver cap, every stroke saves you money.

Key benefits

■ Longer lasting

Nylatron® GSM 12P pile driver caps last much longer than conventional fillers; around 20 to 50 times as long, depending on the type of work and conditions of the soil.

■ Easy to replace

The Nylatron® GSM 12P filler can be quickly and easily replaced at the end of its useful life. There is no need to cut the filler loose or burn it out.

■ Versatile

Nylatron® GSM 12P fillers can be used for virtually any type of piling work; in a diesel hammer and steam hammer, and also for prefab-piling and vibro-piling.

■ The 'right' elasticity

Years of practical experience and research have demonstrated that Nylatron® GSM 12P has the right properties. The force of the blow is effectively transmitted without damaging the pile or the piling hammer.

■ Shorter piling time

With Nylatron® GSM 12P unique material properties, less energy is lost than with conventional materials. With Quadrant Engineering Plastic Products (Quadrant EPP) driver pads, piles can be driven faster and with greater force than ever before.

Distributed by:  Polymershapes

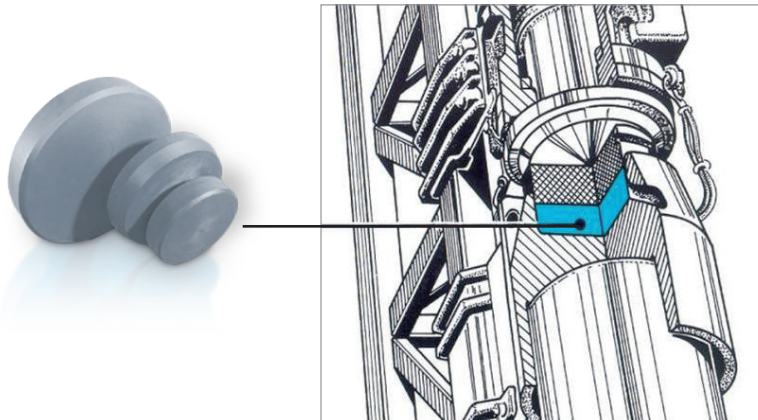

Challenge

In a Middle East project a city had to expand its seaport to increase its export capacities for oil. A massive land reclamation project was started in the harbour area.

Requirements

In order to stabilize the reclaimed ground the project management decided to use huge hydraulic hammers that compact the ground for future export capacities and construction. Hydraulic hammers traditionally worked with energy transferring fillers whose performance and life time was very limited.

Benefits

Quadrant's Nylatron® GSM 12P pile driver caps are used in the hammers to transfer the energy from the hammer into the compacting plate. The purpose of the product is to reduce the high peak loads, hence to avoid the damage of the piling hammer and the compacting plate. The number of impacts per footprint varies throughout the site from 40 - 100 dependent on the local conditions.

Quadrant Engineering Plastic Products

Distributed by:  **Polymershapes**

Call: 1 (866) 437-7427
 Email: info@polymershapes.com
www.polymershapes.com

This brochure and any data and specifications presented here or on our website shall provide promotional and general information about the Engineering Plastic Products (the „Products“) manufactured and offered by Quadrant Engineering Plastic Products („Quadrant“) and shall serve as a preliminary guide. All data and descriptions relating to the Products are of a general informational nature only. Neither this brochure nor any data and specifications presented on our website shall create or be implied to create any legal or contractual obligation. This brochure and any data or specifications herein do not create expressly or by implication any legal, contractual or warranty obligation whatsoever. No warranty of any kind, either express or implied, is made as to the information contained in these pages, including, but not limited to, all warranties provided for by Louisiana law, any implied warranty of merchantability, of fitness for a particular purpose, and any warranty against hidden defects or redhibitory defects or vices. No information in this brochure creates any express or implied warranty that the goods described here in shall conform to any description herein. Quadrant sells the products described herein solely to sophisticated users and not to consumers, and Quadrant assumes no responsibility that any goods described herein will be fit for any particular purpose for which a Quadrant customer may determine to purchase such goods, except and to the sole extent otherwise provided in a separate written contract.

Any illustration of the possible fields of application of the Products shall merely demonstrate the potential of these Products, but any such description does not constitute any kind of covenant or warranty whatsoever. Irrespective of any tests that Quadrant may have carried out with respect to any Product, Quadrant does not possess expertise in evaluating the suitability of its materials or Products for use in specific applications or products manufactured or offered by the customer respectively. It thus remains the customer's sole responsibility to test and assess the suitability and compatibility of Quadrant's Products for its intended applications, processes and uses, and to choose those Products that according to its assessment meet the requirements applicable to the specific use of the finished product. The customer undertakes all liability in respect of the application, processing or use of the aforementioned information or product, or any consequence thereof, and shall verify its quality and other properties.

Nylatron® is a registered trademark of the Quadrant Group.